

ULTRASONIC HEATING/COOLING METER

QALCASONIC HEAT 1



Application

The ultrasonic meter for heating and cooling QALCASONIC HEAT 1 is designed for measuring heating and cooling energy and the recording of data in two separate registers.

It is intended for commercial accounting of energy consumption in objects of local or district heating systems: in dwelling houses, office buildings as well for industrial applications.

- Static liquid metering using ultrasonic technology
- High accuracy
- Heating/cooling
- AMR

Special features

- Accuracy class 2
- Nominal flow 0.6/ 1 /1.5/ 2.5 / 3.5 /6.0 /10 /15 m³/h
- Dynamic range up to $Q_p/Q_i = R 100/250$
- No straight sections required
- No measurement of air
- Environment protection class C
- Protection class: IP65 calculator / IP67 flow sensor
- Nominal pressure PN16/25 bar
- Pressure P25/63
- Temperature measurement Pt500, 0 °C ... 180 °C
- Temperature of conveying liquid: 5 °C ...130 °C
- Metering archive
- Battery lifetime > 12 years
- Power supply options: Battery/External
- Optional communication modules
- Mounting in any installation position
- WMBUS modes: Axis (bidirectional), S1 and T1 OMS
- "Walk By", "Drive By"
- Selectible glycol fluoride type

Measuring accuracy class 2

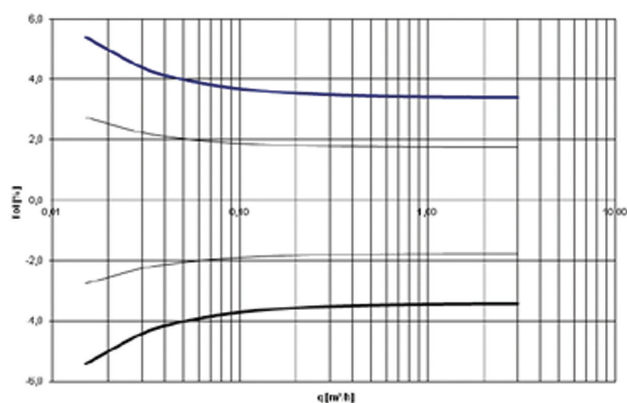

Pressure drop curves

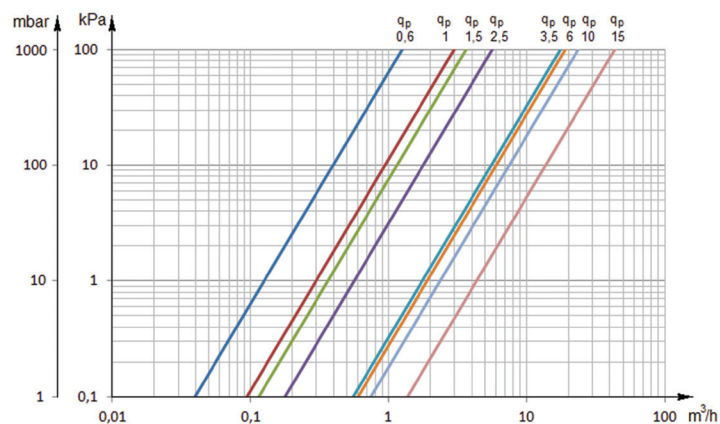

Approvals

MID type approval available
Compliance to the standard EN1434 „Heat meters“

AMR Interfaces

Optical
Radio 868 MHz
M-Bus/CL
LON
MiniBus
Pulse output
MODBUS RS485

Optical interface

Integrated into the front panel of calculator. It is designed for data reading via M-bus protocol and parameterization of the meter.

Radio interface

The internal radio provides data reading via WMBUS telegram:

- Current total Energy
- Current flow
- Current date and time
- Accounting date information
- Error date

Wired M-BUS interface

The internal M-BUS module provides data reading possibility via M-Bus protocol.

Data registration

Hourly, daily and monthly parameter values

- Integrated energy
- Integrated cooling energy
- Integrated energy of tariff
- Integrated volume of liquid
- Integrated pulse value in pulse input 1/2
- Maximum thermal power value for heating/cooling and date
- Maximum value of flow/return temperature of heat conveying liquid and date
- Minimum value of flow/return temperature of heat conveying liquid and date
- Minimum value of temperature difference and date
- Average value of flow/return temperature of heat conveying liquid
- Operating time without an error
- Total error code
- Time when the flow rate exceeded 1.2 Qs
- Time when the flow rate was less than Qi

Universal pulse inputs/outputs

- Pulse cable (optional)
- Two configurable pulse outputs/inputs
- Flow direction indication

ERROR codes

EERROR code indication in case of errors.

Data logger – history values

- Every hour, day and month values of the measured parameters are stored in internal memory
- All data from archive can be read by means of the remote reading
- In addition data logger records of monthly parameters can be seen on the display

LCD indicator:

- The device is equipped with 8-digits LCD (Liquid Crystal Display) with special symbols to display parameters, measurement units and operation modes
- The following information can be displayed:
 - integral and instantaneous measured parameters,
 - archive data and set day data,
 - device configuration information,
- Programmable LCD displaying parameters



Power supply:

Power supply (one of following depending on meter configuration):

- AA battery 3,6 V 2,4 Ah (Li-SOCl₂) battery, operation time at least 11 years,
- 12..42 V DC or 12...36 V 50/60Hz AC external power supply, used current 10 mA and back up battery AA 3,6 V (Li-SOCl₂), operation time at least 11 years (without reading data through digital interfaces).
- 230 V (+ 10% - 30%) 50 / 60Hz AC power supply, current consumption is not more than 10 mA, the meter should be equipped with external power supply unit and an external transformer TRS.

Technical data

Flow rate sensor	Qp [m ³ /h]	0.6 / 1.0 /1.5 /2.5 / 3.5 / 6.0 /10 /15
	R qp/qi [m ³ /h]	100/250
	Medium Temp. (operating temperature)	0,1 ... 130°C
Technical data	LCD-Display	8-digit
	Protection class [IP]	IP65 calculator / IP67 flow sensor
	Environment protection	Class C / EN 1434-1
	Ambient temperature	+5 °C...+55 °C
	Installation place	indoor, outdoor in a pit or inst. box
	Installation position	all installation positions (vertical, horizontal, rising pipe, down pipe)
	Nominal pressure [bar]	PN16/25 bar
	Pressure loss	0.63 / (0.25) bar
	Flow sensor cable length	1,2m (2,5m or 5 m – special order)
	Temperature sensor, two-wire connection, cable length	Up to 5m.
	Battery lifetime	10-12 years
Mounting of calculator	Mounting on standard DIN-rail	

Permanent flow rate q_p , m^3/h	Upper flow rate q_s , m^3/h	Lower flow rate q_i , m^3/h	Threshold value of flow rate, m^3/h	Overall length L, mm	Pressure losses at q_p , kPa	Dynamic range R, Q_p / Q_i	Joining to the pipeline (Thread – G, flange–DN)
0,6	1,2	0,006	0,003	110	7	100	G3/4"
0,6	1,2	0,006	0,003	190	0,9	100	G1" or DN20
1,0	2,0	0,01	0,005	110	11,3	100	G3/4"
1,0	2,0	0,01	0,005	190	2,5	100	G1" or DN20
1,5	3,0	0,006	0,003	110	17,1	250	G3/4"
1,5	3,0	0,006	0,003	190	5,8	250	G1" or DN20
1,5	3,0	0,015	0,003	110	17,1	100	G3/4"
1,5	3,0	0,015	0,003	190	5,8	100	G1" or DN20
1,5	3,0	0,015	0,005	130	7,2	100	G1"
2,5	5,0	0,01	0,005	130	19,8	250	G1"
2,5	5,0	0,01	0,005	190	9,4	250	G1" or DN20
2,5	5,0	0,025	0,005	130	19,8	100	G1"
2,5	5,0	0,025	0,005	190	9,4	100	G1" or DN20
3,5	7,0	0,035	0,017	260	4	100	G1 1/4" or DN25
6,0	12,0	0,024	0,012	260	10	250	G1 1/4" or DN25
6,0	12,0	0,06	0,012	260	10	100	G1 1/4" or DN25
10,0	20,0	0,04	0,02	300	18	250	G2" or DN40
10,0	20,0	0,100	0,02	300	18	100	G2" or DN40
15,0	30,0	0,06	0,03	270	12	250	DN50
15,0	30,0	0,15	0,03	270	12	100	DN50

Dimensions of calculator

117 mm x 44 mm x 89,5 mm,

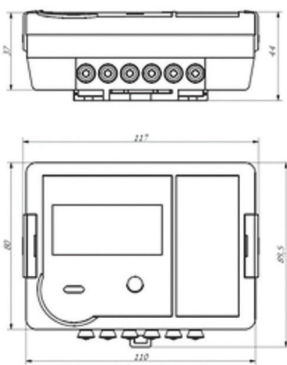

Sizes and dimensions of heat meter

Example – flow sensor $Q_3 = 1,6/2,5 m^3/h$, Threaded end connections G3/4", mounting length $L = 110$ mm.

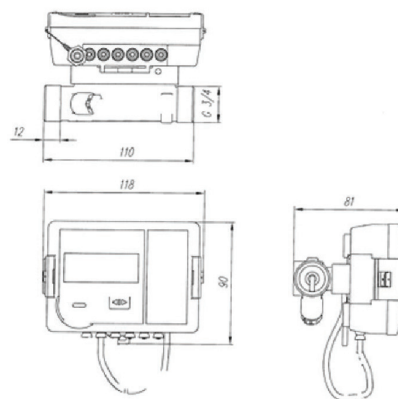

DN [mm]	15	20	25	40	50
L [mm]	110	130/ 190	260	300	270
H [mm]	81	85	123/134	141/163	167
G / Flange DN	G3/4"	G1" or DN20	G1 1/4" or DN25	G2" or DN40	DN50